



ENVASES SANZ BELDA, S.L.

Tel.: 34 96 236 02 32 - calidad@envasesanzbelda.es - www.envasesanzbelda.es
Pol. Ind. San José. Avda, Valencia, parc. 7 - Apdo. de Correos 46 - 46812 Aielo de Malferit, Valencia. (España)



Technical comercial data ref.

M.N-3.5 T.E-4

Serie MASTER NOVA – Versión 07-02-2024

TECHNICAL DATA:

Material:	PP copolymer of first quality, suitable for contact with food according to current regulations.
Colours:	White standard. Consult for other colours.
Useful Volume:	3.5 litres
Volume to the edge:	4.2 litres
Weight of the bucket:	154 g. approx.
Weight of the lid:	52 g. approx.
Weight of the handle (plastic):	8 g. approx.
Total Weight:	214 g. approx.
Decorative surface flat inks:	110 x 555 mm (height x perimeter)
Design surface photographic finish:	123 x 570 mm (height x perimeter)



MEASUREMENTS:

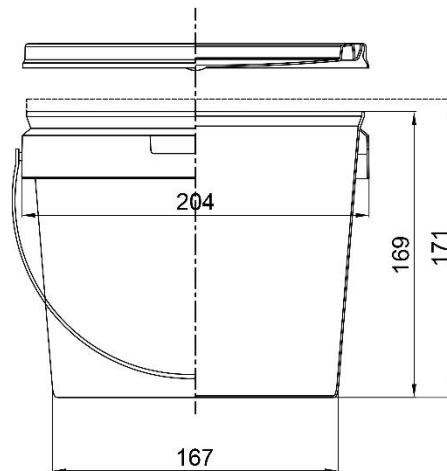

Medidas expresadas en milímetros

AGRUPACIÓN DE TRANSPORTE:

Buckets:	1020 buckets per pallet
Pallet dimensions:	1250 x 1025 x 1070 (see drawing)
Lids:	204 lids per box, this serves as a packaging of transportation
Box dimensions:	420 x 220 x 1000

